

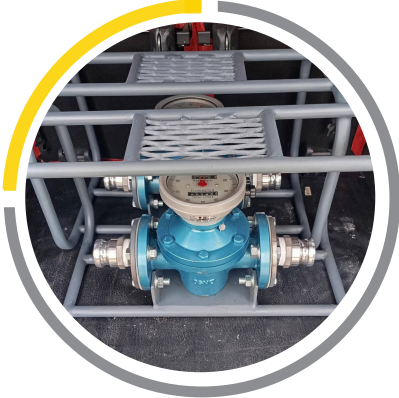

OVAL GEAR FLOW METERS

FOR ACCURATE MEASUREMENT OF VALUABLE FUELS AND LIQUIDS



TACO

When Accuracy Counts®



THE ORIGINAL OVAL GEAR METER

Oval gear flow meters are a type of positive displacement flowmeter widely used in various industrial applications for liquid flow control. They are suitable for measuring different types of liquids, such as crude oil, diesel, petrol, and others. These flow meters offer a wide measurement range, high accuracy, and are easy to use and maintain.

They are available in various material options to meet the requirements of industries such as petroleum, chemical, pharmaceutical, food, metallurgy, power generation, and transportation.



LOW PRESSURE DROP

~2.3 PSI

*avg. based on flowrate

WIDE RANGE TEMP

-40° TO 160°

(-40° to 71°C)

FULL FLOW RANGE

6 -1000 GPM

(20 to 3780 LPM)

INDUSTRIAL APPLICATIONS

Oil Exploitation, Chemical Purification, Bitumen Flowmeter

Oil Industry

In the oil industry, oval gear flow meters are widely used for liquid flow control. They can accurately measure the flow of crude oil, diesel, gasoline, and other petroleum products.

Chemical Industry

In the chemical industry, oval gear flow meters measure acids, alkalis, and organic liquids with high accuracy, a wide range, and low pressure drop.

Pharmaceutical Industry

In the pharmaceutical industry, oval gear flow meters provide high accuracy and reliability, making them suitable for drug production, inspection, and other processes.

Energy Industry

In the energy industry, oval gear flow meters measure the flow of energy resources such as crude oil and natural gas, ensuring a stable supply.



MOST SUSTAINABLE ACCURACY! (COMPARED TO CONVENTIONAL METERS)

Precision-machined gears with minimal mechanical wear inside the measuring chamber ensure consistent accuracy retention over time, reducing the need for frequent re-calibrations and extending service life.



MAIN TECHNICAL PARAMETER

Transmitter Type	Pointer with zero returning, (On Request : Pointer display with Output; LCD)
Medium	Kerosene, Light oil, heavy oil, (On request Petroleum, Vegetable Oil, Food, Chemicals)
Accuracy	± 0.5%, (On request : ± 0.2%)
Nominal Diameter	DN 15–DN 200 mm
Nominal Pressure	1.6 Mpa
Medium Temperature	-20°C ~ 100°C (optional : up to 200°C)
Medium Viscosity	3–200 MPa.s
Power Supply	(On Request : 12V.DC; 24V.DC)
Output Signal	(On Request : Pulse; 4-20mA.DC; RS485)
Display	Accumulative Flow, Single Measurement (Mechanical Dial); Remote transmission of total and instantaneous flow.
Error Adjustment	Changing Gear Adjustment
Level Of Protection	IP65
Explosion Proof	(On Request : Flame-proof Type, ExdIIBT4)
Ambient Temperature	Ambient Temperature
Rotor Material	Cast Iron (on Request : Cast Steel, Stainless Steel)
End Connection	End Connection

MOST SUSTAINABLE ACCURACY!

(COMPARED TO CONVENTIONAL METERS)

Stated accuracy obtainable when all variables remain constant. Reading/measurements reflect a minimum of one minute of flow at selected rate(s). All accuracy statements based on metering safety solvent (aliphatic hydrocarbon), approximate viscosity 1 CPS. On higher viscosity products, the average deviation in accuracy will be less.



RANGE & SPECIFICATIONS

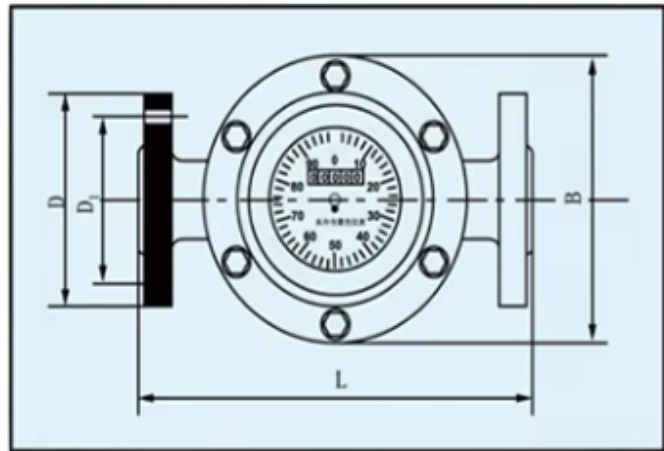
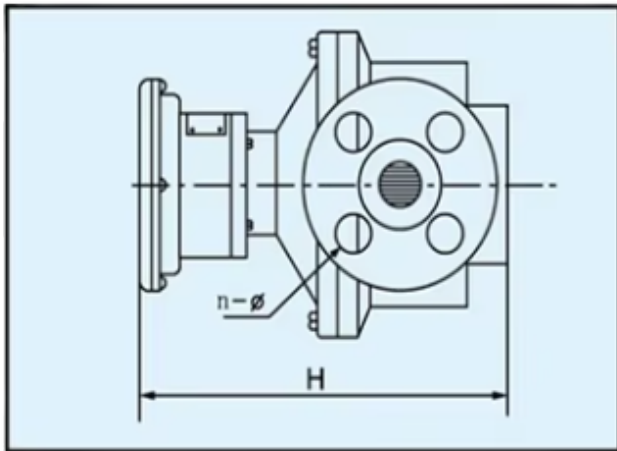

Model	TC25	TC40	TC50	TC80	TC100	TC150
DN(mm)	25	40	50	80	100	150
Min. Flow Rate (m ³ /h)	1	1.6	3	8	16	32
Max. Flow Rate (m ³ /h)	6	16	20	50	100	190
Accuracy (%)	± 0,2 or ±0,5					
Working Temperature °C	-20 – 100					
Pressure (MPa)	1.6					
Liquid Viscosity (MPa.s)	3 – 200					
Min. Scale Value (L)	0.1 1 10					



To learn more about TACO Meter visit:
TCMeter.com

MOST SUSTAINABLE ACCURACY!

(COMPARED TO CONVENTIONAL METERS)

Stated accuracy obtainable when all variables remain constant. Reading/measurements reflect a minimum of one minute of flow at selected rate(s). All accuracy statements based on metering safety solvent (aliphatic hydrocarbon), approximate viscosity 1 CPS. On higher viscosity products, the average deviation in accuracy will be less.