

PT-Series

Sliding Vane Petroleum Pumps
For Refined Petroleum Products and Industrial Solvents

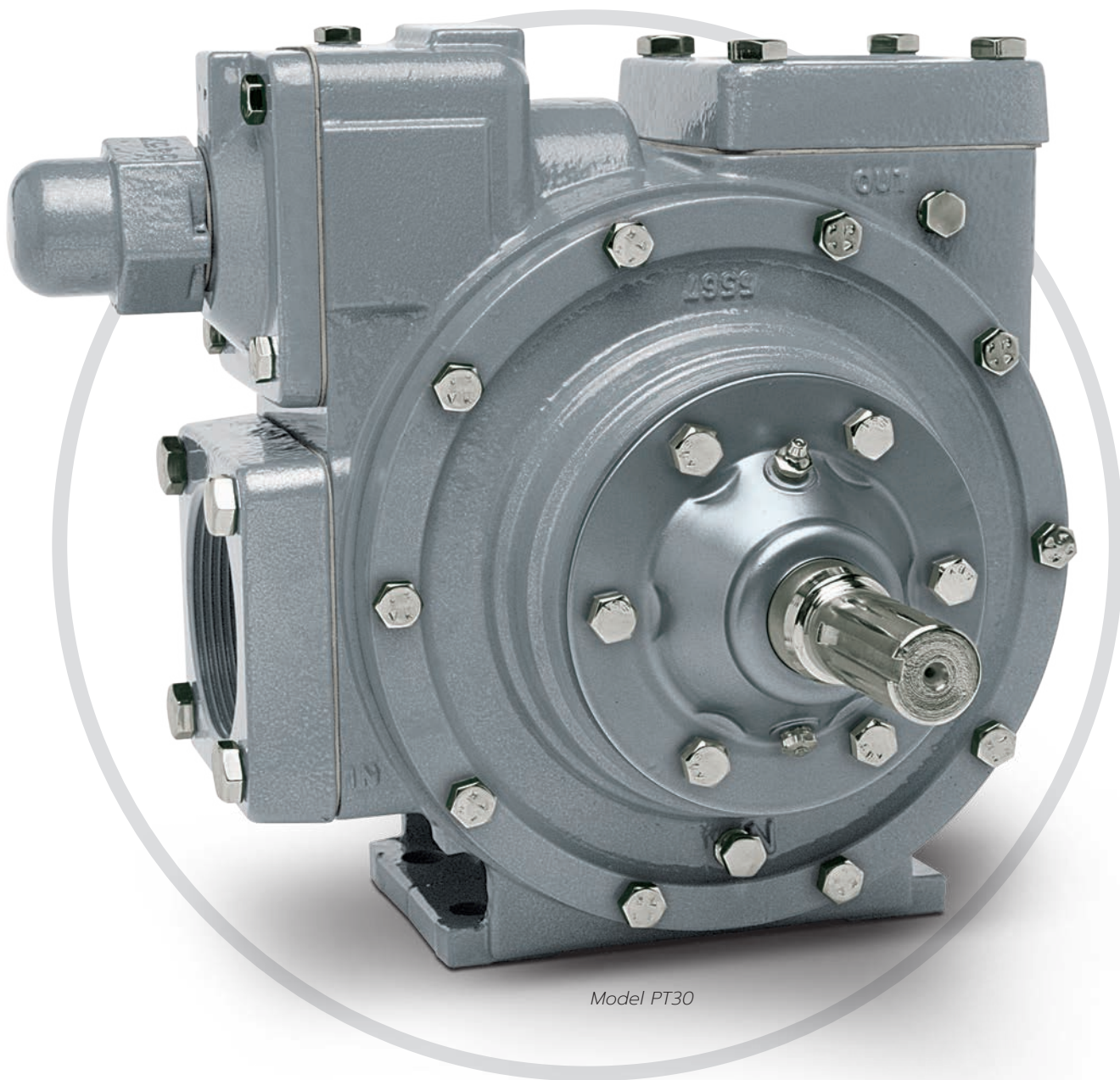

Model PT30

CORKEN[®]
A Unit of IDEX Corporation

A Single Source for Stationary & Mobile Solutions...

Combine a pump, meter, and register on one order...

Corken and Liquid Controls provides a single source solution for transporting, dispensing, and measuring high value fluids and gases. Common corporate ownership and shared distribution simplifies the procurement process. Rather than placing multiple orders, customers are able to combine a pump, meter, and register into a single order.

Dimensionally interchangeable...

PT-Series petroleum pumps offer bulk plants and delivery vehicle systems another choice. To aide bulk plant designers, delivery truck fabricators, and end-user fuel marketers, each pump is dimensionally interchangeable with the competition allowing easy incorporation into existing bulk plant and delivery vehicle systems.

Features

- 1 Viton[®] elastomers are compatible with a wide range of fluids.
- 2 Nickel plated bypass valve is corrosion resistant.
- 3 Available with a standard bypass valve or an optional air operated valve (AOV).
- 4 Mechanical seal is built for lasting performance.
- 5 Heavy duty ball bearings improve durability.
- 6 Hollow rotor reduces weight.
- 7 Dimensionally interchangeable with the competition.
- 8 Drain plug is conveniently located making it easy to empty the pump.
- 9 Vanes self-adjust to compensate for wear.

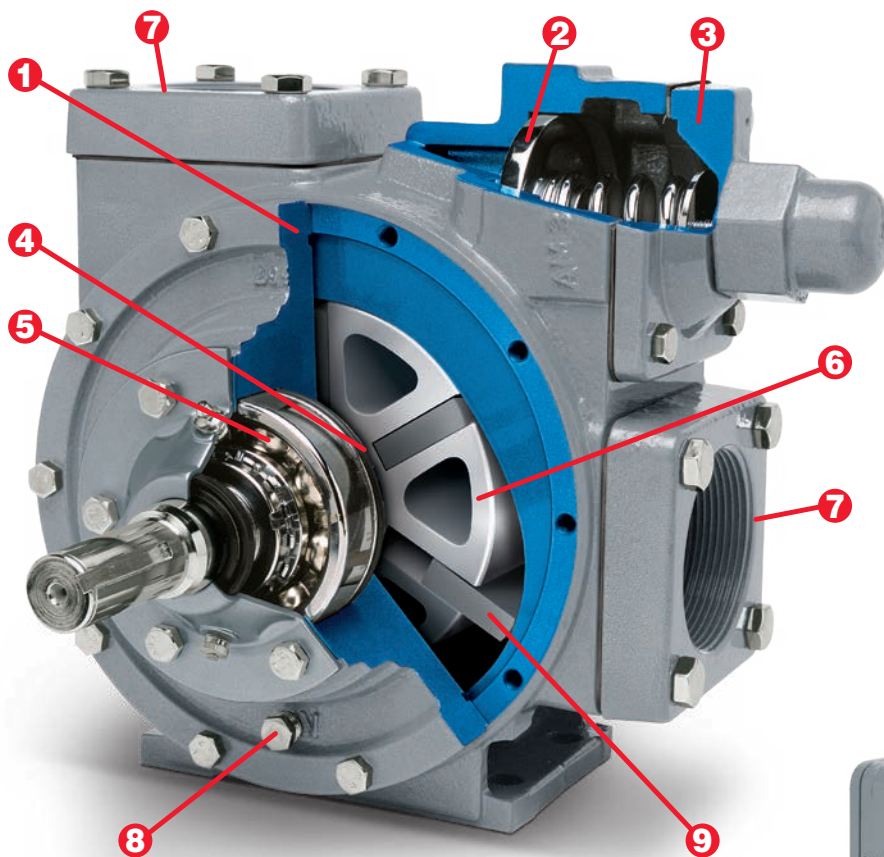

Model PT30

Air operated valve (AOV)...

With the optional air operated valve, a truck operator can increase or decrease the flow rate to match the tank size. Unlike an internal relief valve, the AOV has high and low flow settings. High flow is used for large bulk tanks and low flow for small tanks.

T-Style strainer...

The optional T-Style strainer has a 20 mesh screen that protects the pumping system from the damaging affects of welding slag and foreign materials left in the piping or truck tank.

Pump accessories



Optional Air Operated Valve (AOV)

Optional T-style Strainer

¹ Registered trademark of the DuPont company.

For Refined Petroleum Products & Industrial Solvents

Applications

- Fuel oil deliveries
- Aviation refuelers
- Fleet refueling
- Bulk transfer
- Lube oil deliveries
- Bulk loading and blending

Liquids

- Petrochemicals
- Ethanol
- Gasoline
- Solvents
- Biofuels
- And many more



Model PT20

The model PT20 comes with 2 inch flanges and is ideal for "lube oil" deliveries with smaller flow rates. Applications include deliveries to auto service centers such as dealerships and quick lube companies.



Model PT20



Model PT25

The model PT25 comes with 2.5 inch flanges and is suited for transporting gasoline, diesel, fuel oil, and other petroleum products. The flow rates are perfect for home, farm, and fleet fueling applications.

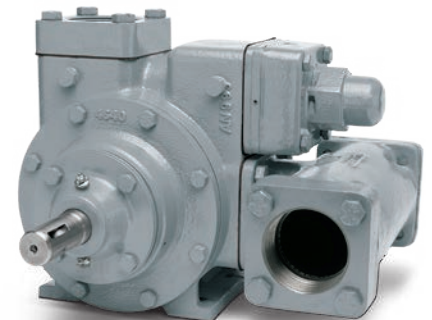

Model PT25



Model PT30

The model PT30 comes with 3 inch flanges and is designed for high flow bulk delivery applications such as aviation fuels, gasoline, diesel, ethanol, biodiesel, and many more.



Model PT30

Specifications

Maximum Specifications Chart

Model	Flow GPM (L/min)	Pump Speed RPM	Viscosity SSU (cP)	Differential Pressure psi (bar)	Working Pressure psi (bar)	Temperature °F (°C)
PT20	88 (333)	780	20,000 (4,250)	125 (8.6)	200 (13.8)	300 (149)
PT25	159 (602)	780	20,000 (4,250)	125 (8.6)	200 (13.8)	300 (149)
PT30	271 (1,026)	640	20,000 (4,250)	125 (8.6)	200 (13.8)	300 (149)

Performance Data¹

Model	PT20		PT25		PT30	
RPM	520	640	520	640	520	640
GPM (L/min)	58 (220)	72 (273)	98 (371)	120 (454)	211 (799)	263 (995)
HP (kW)	2.5 (1.9)	3.0 (2.2)	3.8 (2.8)	5.0 (3.7)	7.8 (5.8)	9.5 (7.1)

Outline Dimensions

Model	A	B	C	D	E	F	G	H	I	J	K	L
PT20	1.125 Dia. (28.6)	5.18 (131.6)	4.00 (101.6)	3.63 (92.2)	0.81 (20.6)	0.81 (20.6)	1.75 (44.5)	1.75 (44.5)	8.00 (203.2)	8.00 (203.2)	6.08 (154.4)	1.50 (38.1)
PT25	1.125 Dia. (28.6)	6.64 (168.7)	4.00 (101.6)	3.63 (92.2)	1.50 (38.1)	1.50 (38.1)	2.45 (62.2)	2.45 (62.2)	9.45 (240.0)	8.75 (222.3)	6.80 (172.7)	1.75 (44.5)
PT30	1.125 Dia. (28.6)	6.93 (176.0)	5.38 (136.7)	4.25 (108.0)	1.25 (31.8)	1.25 (31.8)	2.19 (55.6)	2.19 (55.6)	9.63 (244.6)	9.63 (244.6)	8.60 (218.4)	2.50 (63.5)

Model	M	N	O	P	Q	R	S	T	U	V	W
PT20	4.98 (126.5)	4.13 (104.9)	0.50 (12.7)	0.44 Dia. (11.2)	2.50 (63.5)	2.50 (63.5)	3.31 (84.1)	3.31 (84.1)	3.90 (99.6)	3.90 (99.6)	5.30 (134.6)
PT25	6.35 (161.3)	5.06 (128.5)	0.25 (6.35)	0.44 Dia. (11.2)	2.75 (69.9)	2.75 (69.9)	3.50 (88.9)	3.50 (88.9)	4.31 (109.5)	3.87 (98.3)	6.05 (153.7)
PT30	6.44 (163.6)	5.31 (134.9)	0.75 (19.1)	0.63 Dia. (16.0)	3.00 (76.2)	3.00 (76.2)	3.63 (92.2)	3.63 (92.2)	5.00 (127.0)	4.95 (125.7)	6.43 (163.3)

¹ Capacities and horsepower are based on a 100 SSU (22 cP) fluid at 50 psi (3.4 bar) delivered pressure. Refer to performance curves in the PT-Series sales catalog or the installation, operation, and maintenance (IOM) manual for flow rates at other pressures.

All dimensions in inches (millimeters)

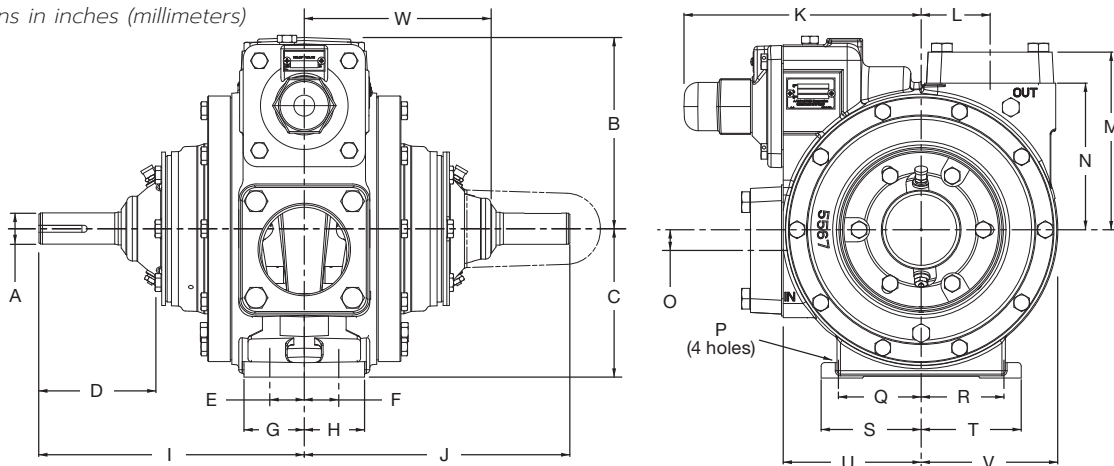

Solutions beyond products...

CORKEN®

CORKEN, INC. • A Unit of IDEX Corporation
 9201 North I-35 Service Road, Oklahoma City, OK. 73131 U.S.A.
 Phone (405) 946-5576 • FAX (405) 948-7343
 Website: www.corken.com
 E-mail: cocsalesdept@idexcorp.com



@CorkenInc

