

Atmos[®] - Compact type gas meter

Two-pipe Diaphragm gas meter G1.6MA | G2.5MA



Solid build quality, high accuracy, safety and a series of advanced technical details make the Atmos[®] diaphragm gas meter a high-grade measuring instrument. The Diaphragm gas meter is available in sizes G1.6 and G2.5. The meter is characterized by precise measurements, a constant measuring stability, a long life and high reliability. Thanks to the use of high-grade materials, the diaphragm gas meter is resistant to corrosion.

The gas meter is suitable for various gas media. The integrated calibration system coordinates the movement of the valves in relation to the optimum gas flow. The excellent linearity of the error curve is guaranteed even at low flow rates. Due to the optimum rotating characteristics of the valves the Q_{min} value remains stable and the gas meter is resistant to contamination.

The Atmos[®] diaphragm gas meter meets the requirements of the EN1359:1998/A1:2006 and OIML R137-1 (2012) standards.

Sizes:

G1.6MA : 0.016 m³/h to 2.5 m³/h

G2.5MA : 0.025 m³/h to 4 m³/h

Gas media:

- Natural gas
- Town gas
- Liquid gas
- Methane gas

Housing material:

Die-cast aluminum

Performance characteristics

- Approved in accordance with MID by NMI
- Integrated system to adjust the error curve
- 0.8dm³ cyclic volume, suitable for the demand of G1.6 & G2.5
- Long-term accurate measurement
- Working temperature range: -25 °C to +55 °C
- Anti-corrosion performance
- Starting flow ≤ 1 dm³/h
- Retrofittable with pulser

Technical data Atmos®G1.6MA | G2.5MA

Type			G1.6MA	G2.5MA
Nominal flowrate	Q_n	m ³ /h	1.6	2.5
Maximum flowrate	Q_{max}	m ³ /h	2.5	4
Minimum flowrate	Q_{min}	m ³ /h	0.016	0.025
Maximum operating pressure		bar	0.5	0.5
Maximum permissible errors	$0.1 Q_{max} \leq Q \leq Q_{max}$ $Q_{min} \leq Q < 0.1 Q_{max}$		± 1.5% ± 3%	± 1.5% ± 3%
Max. pressure loss		mbar	≤ 2	≤ 2
Display range max.		m ³ /h	99999.9998	99999.9998
Display range min.		m ³ /h	0.0002	0.0002
Accuracy class	class		1.5	1.5
Cyclic volume		dm ³	0.8	0.8
Pulse value		m ³ /pulse	0.01	0.01
Weight		kg	1.55	1.55

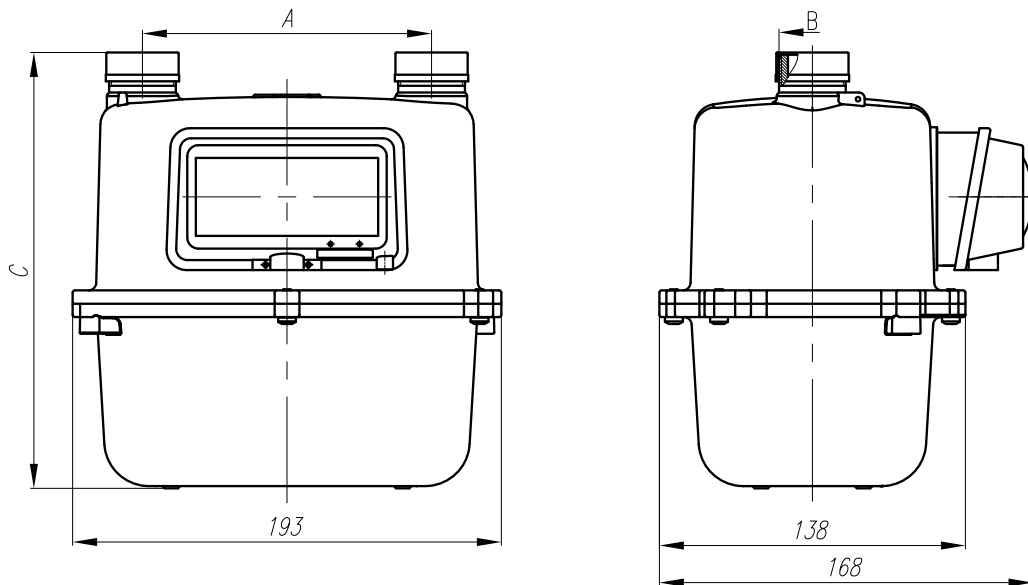

Dimensions Diaphragm gas meter Atmos® G1.6MA | G2.5MA

A	[mm]	110 ± 0.50	130 ± 0.50	
B		M30 x 2 - 6 g	M26 x 1.5- 6 g	NPT ¼"
C	[mm]	196		